

IVECO



The right move.

e SUPER
JOLLY

Discover the **new 100% electric** **eSUPERJOLLY.**

*UP TO 62 MILES CHARGE
IN JUST 15 MINUTES*

*UP TO 261 MILES RANGE WITH
THE 110kW HIGH-DENSITY BATTERY**

*BEST PAYLOAD / BATTERY RATIO
AND OPTIMISED DIMENSIONS*

*LOAD VOLUME UP TO 17m³
AND BEST VOLUME / LENGTH RATIO*



* WLTP range based on simulations using homologation parameters. Actual range may vary depending on driving style, weather conditions, and other external factors.

Electric Power. Professional Purpose.



100% FULLY ELECTRIC

Covers most delivery missions with long range and fast charging.

EXCELLENT LOAD CAPACITY

Wide volumes and high payload, at zero emissions.

COMFORT AND SAFETY

Feel safe with level 2 ADAS and enjoy the roomy and high-tech interiors.

ENHANCED PRODUCTIVITY

Keep your vehicles ready and streamline your operations with IVECO Services.

100% Electric,
100% Payload.





eSUPERJOLLY is your ideal business ally for navigating urban environments – even in restricted traffic zones.

Powered by a high-capacity 110kWh battery, it offers an impressive range of up to 261 miles* (WLTP), giving you the confidence to manage your daily operations without compromises.

Whether it's last-mile deliveries, logistics, or city-based work, the eSuperJolly keeps you productive, compliant, and moving quietly with zero-emission electric performance.

Powerful, adaptable, and cost-effective.

With three traction modes – Eco, Normal, and Power – you control how the vehicle responds. Choose Power for maximum responsiveness, Normal for a smooth and balanced ride, or Eco for a more efficient and sustainable drive with lower energy consumption.

While on the road, the regenerative braking system boosts efficiency by converting kinetic energy into electric power every time you lift your foot off the accelerator. Four regeneration levels – High, Medium, Low, and Freewheeling – let you tailor deceleration to your preference, from maximum energy recovery to effortless coasting.

* WLTP range based on simulations using homologation parameters. Actual range may vary depending on driving style, weather conditions, and other external factors.

When comfort is part of your work.

Turn every journey into a productive workspace with eSUPERJOLLY – your office on wheels.

Designed for professionals on the move, it offers a spacious, ergonomic cabin with the comfort and functionality you need to perform at your best.

Adjustable headrests, backrests, and lumbar support on the front seats keep you comfortable and focused throughout the day. And when it's time to switch from driving to working, the optional folding centre seat transforms into an adjustable table (FLEX TABLE) – perfect for your laptop, documents, or mobile devices.

Smart storage solutions – from glove compartment and lower drawers to cup holders and large door pockets – keep everything organised and within reach.

With eSuperJolly, your business moves with you.





Smart, connected cabin, built for your workday.

The eSuperJolly keeps you in control with advanced infotainment and connectivity features designed to support your business on the move.

Choose the setup that fits your style:

- The standard 7" touchscreen DAB radio with one or two* USB ports for essential functionality.
- Or upgrade to the 10" full-color touchscreen with DAB, MP3 player and 3 USB ports.

Clearer, safer driving

The RearView Camera provides a wide, unobstructed, and ultra-clear view of the area behind the vehicle, making reversing and parking safer and easier. Together with 360 parking sensors*, it puts you in complete control of the space around the vehicle.

Navigation and Smart Routing

On the 10" touchscreen, the TomTom 3D map guides you, while Apple CarPlay™ and Android Auto™ seamlessly integrate your smartphone. With IVECO's Smart Routing service**, you will always know the most efficient path – and never worry about range again.

Stay focused, stay connected

Use voice commands with the Vocal Assistant** to keep your hands on the wheel and your eyes on the road. Moreover, with wireless Apple CarPlay™ and Android Auto™, available on both screen options, you can navigate, call, message, and stream music from the vehicle's display.

* Optional.

** Available on 10" touchscreen. Requires an active connectivity contract.





Experience seamless comfort and intelligent control with eSUPERJOLLY.

With the Keyless Entry & Go system, you can unlock the cabin and cargo area, and start or stop the vehicle – all without ever reaching for your key. Simply approach the vehicle, and you're ready to drive.

The Electronic Parking Brake (EPB) replaces the traditional handbrake lever with a sleek, intuitive button to securely engage the rear brakes, freeing valuable space in the cabin.



Capacity, autonomy,
sustainability.

IVECO eSUPERJOLLY delivers.



Best-in-class

payload-to-battery range ratio.

The eSUPERJOLLY is the optimal solution for urban delivery operations

With a robust 110kWh battery and best-in-class payload capability up to 1.4 tonnes on 4.25-tonne version, it is designed for professionals who require extended range and high energy capacity.

Whether navigating city streets or handling demanding logistics, the eSuperJolly combines endurance and efficiency to keep your business moving.

Best-in-class

volume-to-length ratio.

Compact in size, big on volume

At a maximum length of 6.36 meters, the eSuperJolly redefines space efficiency with up to 17m³ of cargo volume – a benchmark in its category.

This unique combination of compact dimensions and high volume capacity makes it ideal for urban logistics, where manoeuvrability, ease of parking, and access to restricted areas are essential.

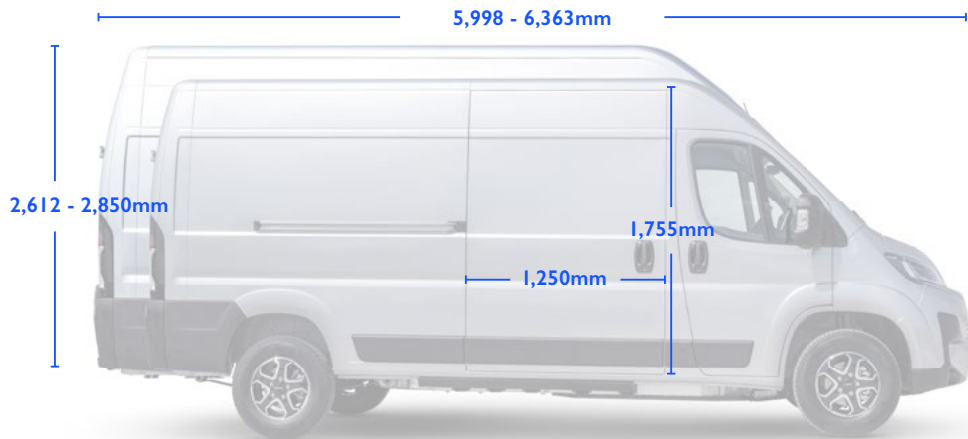

Excellent volume for big loads.

Designed to meet the demands of modern business, the eSuperJolly combines **intelligent design with exceptional cargo capabilities.**

Its optimised shape with vertical sidewalls maximises usable space, making it one of the most efficient vehicles in its class.

The capacious cargo area accommodates up to five Euro-pallets. Wide-opening rear and side doors – including 270° rear doors – and roof-height rear doors make loading and unloading effortless – even in tight city or warehouse environments.

Whether you're navigating city streets or managing high-volume deliveries, the eSuperJolly delivers the perfect balance of compactness, capacity, and convenience.



Charge your eSUPERJOLLY anytime, anywhere – effortlessly.

Fast charging

Whether at home on a standard outlet, connected to a dedicated wallbox, or using a public charging station, powering up is simple. LED indicators on the side provide a clear, intuitive view of charging progress.

Need a quick boost? With 150kW fast charging you can add up to 62 miles of range in just 15 minutes.

Charging made easy

Start with **IVECO eCharge Packs**, the turnkey solution that combines private and public charging in one offer. Power your eSuperJolly at home or in the depot with the premium partner carrying the exclusive quality label “**Recommended by IVECO**”, including a 22kW AC Wallbox made in Europe and fully tested for interoperability, plus DC fast chargers for demanding operations.

Enjoy peace of mind with expert installation and multi-year assistance coordinated by the IVECO Customer Uptime Center, and access 1,000,000+ public points and 10,000+ ultra-fast stations using the IVECO eCharge Card, all managed through IVECO ON and the Easy App. Availability of products and services may vary by country. Please check with your local IVECO dealer.







IVECO

SUPER
JOLLY

Line Up.

Find the perfect ally for your urban mission.

Every city has its challenges – and eSuperJolly is ready for them all. Built for zero-emission performance and maximum flexibility, it's the trusted partner that helps you move efficiently, sustainably and without compromise.

Zero-emission Urban Delivery

Where efficiency meets responsibility. eSuperJolly offers all the versatility and capacity you need to keep your business moving – combining exceptional range and payload performance to make every delivery clean, quiet and cost-effective.

Municipalities & Specialties

From daily operations to demanding tasks, eSuperJolly adapts to every need. With its generous loading volume and optimised cargo space, it's perfectly equipped to carry tools and equipment – empowering professionals to keep the city running smoothly.

Load volume (m ³)	Height (mm)	Length (mm)	Motor (kW)	AC charge / DC charge	Gross vehicle weight - 3.5 tons		Gross vehicle weight - 4.25 tons	
					Payload* (tons)	Battery - Range**	Payload* (tons)	Battery - Range**
13	2,612	5,998	205	22kW / 150kW	0.67 - 0.505	110kWh 235 miles (WLPT)	1.42 - 1.26	110kWh 263 miles (WLPT)
	2,850					110kWh 222 miles (WLPT)		110kWh 254 miles (WLPT)
15	2,612	6,363	205	22kW / 150kW	0.62 - 0.47	110kWh 233 miles (WLPT)	1.37 - 1.22	110kWh 262 miles (WLPT)
	2,850					110 kWh 221 miles (WLPT)		110kWh 252 miles (WLPT)

* Driver's already accounted in kerb weight.

** Data from simulation could change in future.

Your safe place in the urban jungle.

With Level 2 Autonomous Driving, your eSuperJolly utilises its sensors, radar, and camera to continuously monitor the road and surrounding traffic to assist with key driving functions. By helping you maintain safe distances, adapt to changing conditions, and reduce fatigue in demanding situations, it brings you a smoother, safer, and more confident driving experience – so you can focus on enjoying the journey.

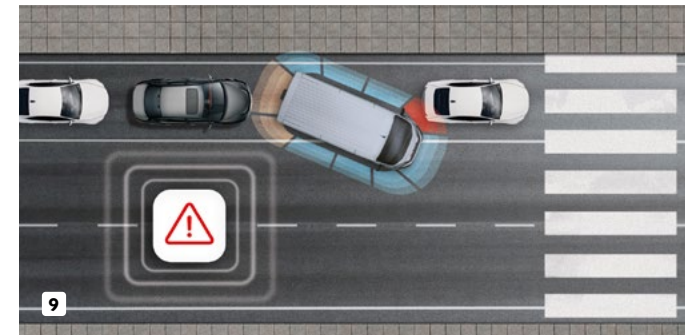
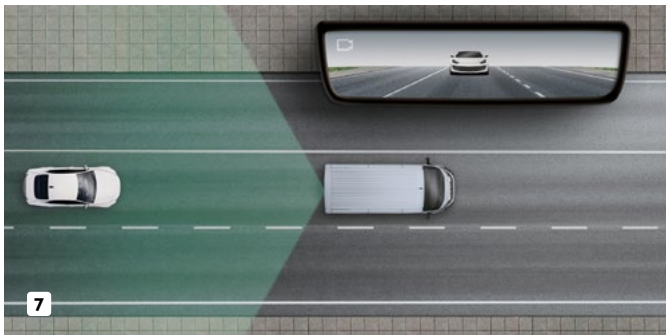
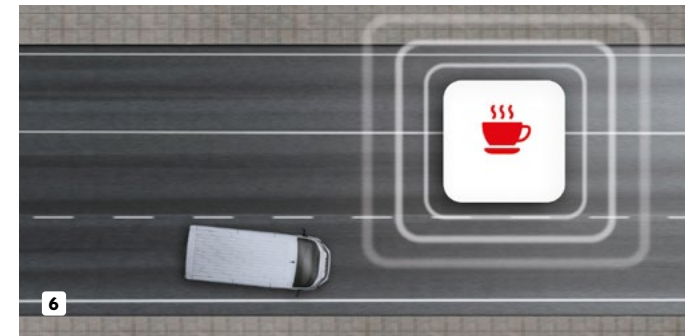
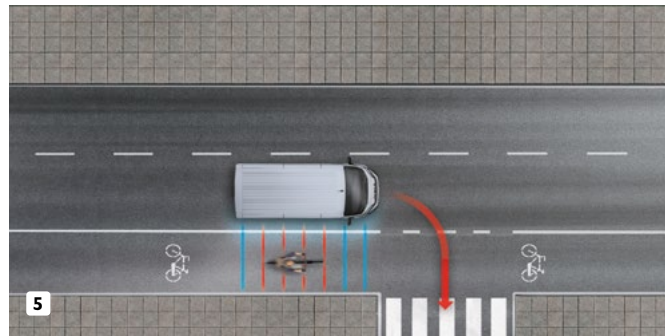
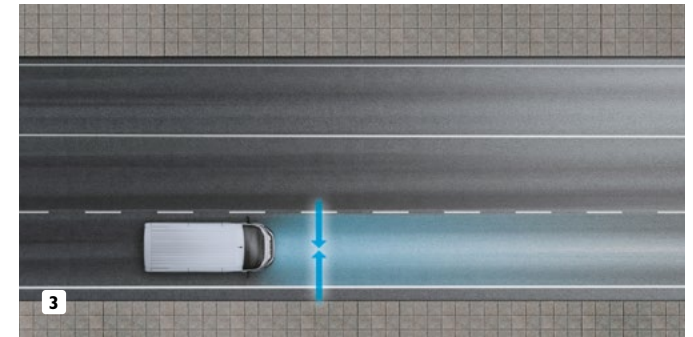
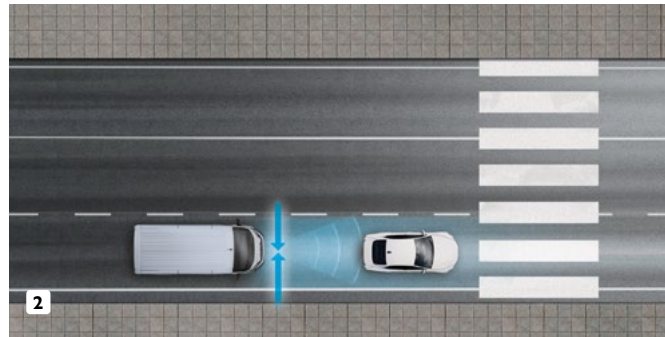
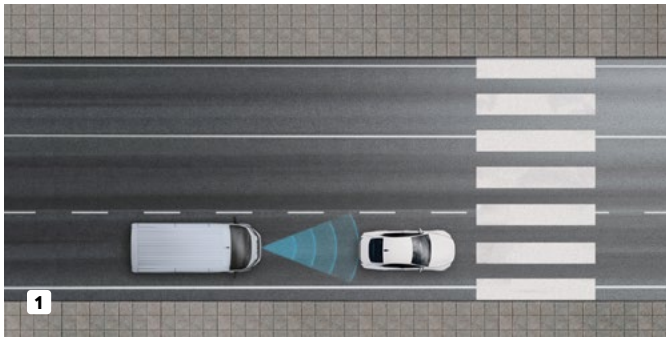



1 ADAPTIVE CRUISE CONTROL STOP&GO

Easily activated via intuitive steering wheel controls, Adaptive Cruise Control Stop&Go automatically sets and adjusts vehicle speed to maintain a safe distance from the vehicle ahead. In case the vehicle ahead stops, it brings your vehicle to a complete stop resuming automatically when traffic begins to move.

2 TRAFFIC JAM ASSIST

Helps you automatically follow the traffic flow, accelerating and braking as needed, and steering to ensure you stay in your lane.

3 LANE CENTERING

Helps prevent unintentional lane departure using a forward-facing camera mounted on the windscreen. When activated and operational, the system monitors lane markings. If no turn signal is detected, it applies gentle steering corrections to keep the vehicle within lane boundaries or away from the road edge. The system provides tactile feedback through steering wheel torque, accompanied by visual and audible alerts on the instrument cluster. An optional Advanced Lane Centering function keeps the vehicle centred in the lane.

4 INTELLIGENT SPEED ASSIST

Helps prevent speed violations by automatically setting the speed limiter based on information from Traffic Sign Recognition. Using the forward-facing camera, the system detects speed limit signs and adjusts the limiter accordingly.

5 BLIND SPOT INFORMATION SYSTEM

Blind Spot Information System allows you to recognise side obstacles inside the blind side area opposite the driver's position, by using a set of camera and radars. The system alerts you with a visual warning on cluster and on mirrors through a triangle sign of alert. For a full control of both sides of your vehicle, you can choose the optional Blind Spot Assist which alerts in case of approaching vehicles or overtaking.

6 ADVANCED DRIVER DISTRACTION WARNING

Enhances road safety by detecting signs of driver distraction, drowsiness or mobile phone use. A discreet camera on the driver-side pillar continuously monitors attentiveness. If fatigue or inattention is detected, the system triggers visual and acoustic alerts, prompting the driver to rest and refocus. Designed in line with the latest GSR-C regulations, it helps prevent accidents while protecting privacy. The system does not record or store facial images, ensuring full compliance with data protection standards.

7 DIGITAL REARVIEW MIRROR

Improves visibility for safety and easy drive. Equipped with a central 8.9" high-resolution LCD display, the system offers a wide, unobstructed, and ultra-clear view of the area behind the vehicle. The view is enabled by a wide-angle HD camera integrated into the center of the upper third stop lamp.

8 REAR PARKING CAMERA

High quality image on the radio display (both 7" and 10" touchscreens), in compliance with GSR regulation. The camera features dynamic grid lines that move in sync with the steering wheel, clearly showing the projected vehicle path to support precise and safe parking maneuvers.

9 360° PARKING SENSORS

Alerts the driver with acoustic and visual warnings when approaching obstacles or navigating tight spaces. The system uses 14 or 16 sensors (depending on vehicle length) positioned around the vehicle—on the front and rear bumpers and side moldings. A visual representation on the cluster displays the vehicle with three surrounding proximity zones, indicating the distance from nearby objects. At the same time, acoustic alerts increase in frequency as the vehicle nears an obstacle, becoming a continuous tone when the distance is less than 30cm.

IVECO Services Solutions.

The complete development of state-of-the-art vehicles is important to provide our customers with Mobility Solutions that best meet their needs. At IVECO, our goal is to improve the productivity and profitability of our customers' businesses. We do this by maximising vehicle uptime and efficiency, driver safety and environmental protection.



Uptime

To maximise your vehicle's uptime by preventing unplanned stops through proactive monitoring and 24/7 roadside assistance. Rely on Aftersales excellence and EV expert support at certified service points, and plan ahead with uptime notifications, maintenance reminders, and tailored Maintenance & Repair contracts.



Driver Care, Safety & Security

To promote a safer driving style, improve the drivers' performance and increase their safety for a better experience behind the wheel.



eMobility

IVECO eMobility services enable you to identify the most efficient routes and charging plans, maximise your vehicle's range with remote controls and optimise uptime and energy efficiency with our timely alerts on your vehicle's remaining charge.



Productivity & Efficiency

To reduce energy, optimise routes and improve your drivers' driving style for a more productive and efficient business with lower running costs.



Parts & Accessories

Our extensive offer of high-quality parts and services enables you to customise your vehicle and enhance your life on board.



Service bundle.

All vehicles come with a connectivity box installed, enabling activation of the Standard eStart Pack and the option to add Premium Mobility Solutions tailored to your business goals (terms and conditions apply).

Standard service bundle.

eStart Pack

Essential tools to monitor and control your EV, boosting productivity, efficiency, and sustainability.

- **IVECO ON Access.** Fleet visibility through the IVECO ON portal for real-time data and simplified management.
- **Easy eJolly App.** Driver-friendly app for quick access to vehicle status, charging points, and key info.
- **Uptime Monitoring and Management.** Continuous health checks and proactive alerts to prevent downtime.
- **eRemote Control.** Schedule and manage charging and comfort features remotely for cost efficiency and readiness.
- **eRange Assurance.** Accurate range prediction and battery alerts for stress-free planning.

Premium services.

Tailor your Mobility Solution with powerful add-ons:

- **IVECO ON WebAPI.** Integrate fleet data into your systems for advanced analytics and automation.
- **IVECO ON Plus.** Location-based services with live vehicle positioning for smarter job planning.
- **IVECO eCharge Management.** Public charging access with IVECO eCharge Card, simplifying admin and cost tracking.

Premium bundles.

Enjoy comprehensive packs for peace of mind, simplified charging, and improved efficiency:

- **IVECO eCharge Pack.** Combines private chargers and public network access in one solution with a single interface and contract.
- **Driver Assistant.** Extends Smart Routing and infotainment features, adding extra years of connected experience.



Repair & Maintenance.

You can protect the value and performance of your vehicle and your business productivity with a Repair & Maintenance offer.

Our maintenance and repair contracts plans will maximise your vehicle availability and you can rely on our skilled workforce and guaranteed high-quality IVECO Genuine Parts.

Combine the R&M services to build a contract tailored to your needs:



MAINTENANCE

Standard Maintenance is key to keeping the vehicle up and running and is required by law. MAINTENANCE is ideal for customers without their own workshop who want to contain costs.

WEAR

All components creating friction will wear over time and will eventually need to be replaced. Avoid surprises with WEAR.

DRIVELINE

DRIVELINE starts with cover of the most valuable components, which are those that transmit movement to the vehicle.

FULL REPAIR

With FULL REPAIR you can enjoy the full peace of mind of knowing anything on your vehicle needing repairs is covered.

Your IVECO eSuperJolly comes with 2-year FULL REPAIR cover included in the standard warranty.

Choose and combine to meet your requirements:

You can choose the best service* levels for your business size and needs, knowing that the associated costs are fixed and predictable.



ESSENTIAL 
Maintenance

ADVANCED 
Maintenance + Driveline

PREMIUM 
Maintenance + Full Repair

FULL REPAIR 
Driveline + Extradriveline

* Wear selectable as option.



Genuine Parts

HIGH PERFORMANCE

IVECO Genuine Parts will keep your IVECO eSuperJolly performing at its best during its long years at your service – and cost-efficiently. With these parts, you will enjoy the peace of mind of knowing they have been rigorously tested for safety, consistency and reliability, and come with a one-year warranty.



IVECO
00800|4|8|3|2|6|000
Assistance Non-Stop



IVECO Assistance Non-Stop is just a phone call away 24 hours a day, 7 days a week to keep your eSuperJolly and your business running.

IVECO Non-Stop is the original IVECO smartphone application that you can use to communicate with IVECO if your vehicle breaks down. Just insert your vehicle information (VIN and registration plate) and with a simple push of a button you can send a request for assistance to the IVECO Customer Uptime Center. We will take care of your request immediately, activate the nearest workshop and follow up on the vehicle's repair. Through the app you can receive updates on the progress of your vehicle's assistance.



IVECO CAPITAL Financial Services

IVECO CAPITAL is the financial services brand of Iveco Group and offers a comprehensive range of solutions for commercial, industrial vehicles and buses. Our customers can build the perfect financial formula* to fit their always evolving needs, modulating financing, insurances and services.

With a long-standing market presence, IVECO CAPITAL is a reliable partner, adding value to our customers' businesses by providing simple, innovative access to a dynamic ecosystem of services.



Discover more on www.ivecocapital.com

Build your ideal formula by contacting your IVECO Dealer or IVECO Direct Sales.

* Subject to IVECO CAPITAL credit approval.



PUBLICATION L2544801UK - 03/26

The information contained in this brochure is based on the best data available to Iveco Group following its internal tests and simulations, pending the vehicle homologation, therefore the information concerning availability and capabilities may be subject to change. Officially homologated driving range will be published closer to the vehicle's sales date, moreover, in every case, the data may vary due to various factors (e.g. truck equipment, driving style, weather conditions, route mission, vehicle condition, age and condition of the lithium-ion battery). The information and images in this brochure are provided as a guideline only. IVECO reserves the right to make changes for any commercial or construction reasons at any time without notice.

Copyright © IVECO. All rights reserved.

Unless otherwise indicated, the texts, images, visual contents, portraits, logos, brands, and trademarks on this document are owned by IVECO or used with third-party permission. Reproduction, modification, or use without prior written consent is prohibited. This content is intended for UK markets.